

---

# UNITRON®

## ZoomHD

DIGITAL MACRO ZOOM  
INSPECTION SYSTEM

INSTALLATION &  
OPERATION  
MANUAL



---

73 Mall Drive, Commack, NY 11725 • 631-543-2000 (P) • 631-589-6975 (F)  
www.unitronusa.com • info@unitronusa.com

# Contents

<b>Introduction</b> .....	2
<b>Safety Notes</b> .....	2
<b>Unpacking &amp; Components</b> .....	2
<b>Care &amp; Maintenance</b> .....	2
<b>Components</b>	
ZoomHD Digital Microscope (with Display) .....	3
ZoomHD Digital Microscope (without Display).....	5
<b>Assembly</b>	
Assembly Diagram .....	7
Detailed Assembly.....	9
<b>Using Your ZoomHD</b>	
Adjusting the Focusing Tension.....	10
Setting Illumination.....	10
Placing the Specimen .....	10
Adjusting the Focus .....	11
Setting the Magnification .....	11
Using the Buttons and Interfaces.....	11
<b>Troubleshooting</b> .....	12
<b>Service</b> .....	13
<b>Warranty</b> .....	13

## INTRODUCTION

Congratulations on the purchase of your new UNITRON® microscope. UNITRON® microscopes are engineered and manufactured to the highest quality standards. Your microscope will last a lifetime if used and maintained properly. UNITRON® microscopes are carefully assembled, inspected and tested by our staff of trained technicians in our New York facility. Careful quality control procedures ensure each microscope is of the highest quality prior to shipment.

## SAFETY NOTES

1. Open the shipping carton carefully to prevent any accessory from dropping and being damaged.
2. Keep the instrument out of direct sunlight, high temperature or humidity, and dusty environments.
3. If any specimen solutions or other liquids splash onto the stage, objective or any other component, disconnect the power cord immediately and wipe up the spillage. Otherwise, the instrument may be damaged.
4. All electrical connectors (power cord) should be inserted into an electrical surge protector to prevent damage due to voltage fluctuations.
5. Confirm that the input voltage indicated on your microscope corresponds to your line voltage. The use of a different input voltage other than indicated will cause severe damage to the microscope.

**NOTE:** Always plug the microscope power cord into a suitable grounded electrical outlet. A grounded 3-wire cord is provided.

## UNPACKING & COMPONENTS

Your microscope arrived packed in a molded shipping carton. ***Do not discard the carton:*** the shipping carton should be retained for reshipment of your microscope if needed. Avoid placing the microscope in dusty surroundings or in high temperature or humid areas as mold and mildew can form. Carefully remove the microscope from the shipping carton and place the microscope on a flat, vibration-free surface.

## CARE & MAINTENANCE

1. Do not attempt to disassemble any component including eyepieces, objectives or the focusing assembly.
2. Keep the instrument clean; remove dirt and debris regularly. Accumulated dirt on metal surfaces should be cleaned with a damp cloth. More persistent dirt should be removed using a mild soap solution. Do not use organic solvents for cleansing.
3. The outer surface of the optics should be inspected and cleaned periodically using an air bulb. If dirt remains on the optical surface, use a soft, lint free cloth or cotton swab dampened with a lens cleaning solution (available at camera stores). All optical lenses should be swabbed using a circular motion. A small amount of absorbent cotton wound on the end of a tapered stick makes a useful tool for cleaning recessed optical surfaces. Avoid using an excessive amount of solvents as this may cause problems with optical coatings or cemented optics or the flowing solvent may pick up grease making cleaning more difficult.
4. Store the instrument in a cool, dry environment. Cover the microscope with the dust cover when not in use.
5. UNITRON® microscopes are precision instruments which require periodic servicing to maintain proper performance and to compensate for normal wear. A regular schedule of preventative maintenance by qualified service personnel is highly recommended. Your authorized UNITRON® distributor can arrange for this service.

# ZoomHD DIGITAL MACRO ZOOM INSPECTION SYSTEM

## Components

### ZoomHD (with Display)

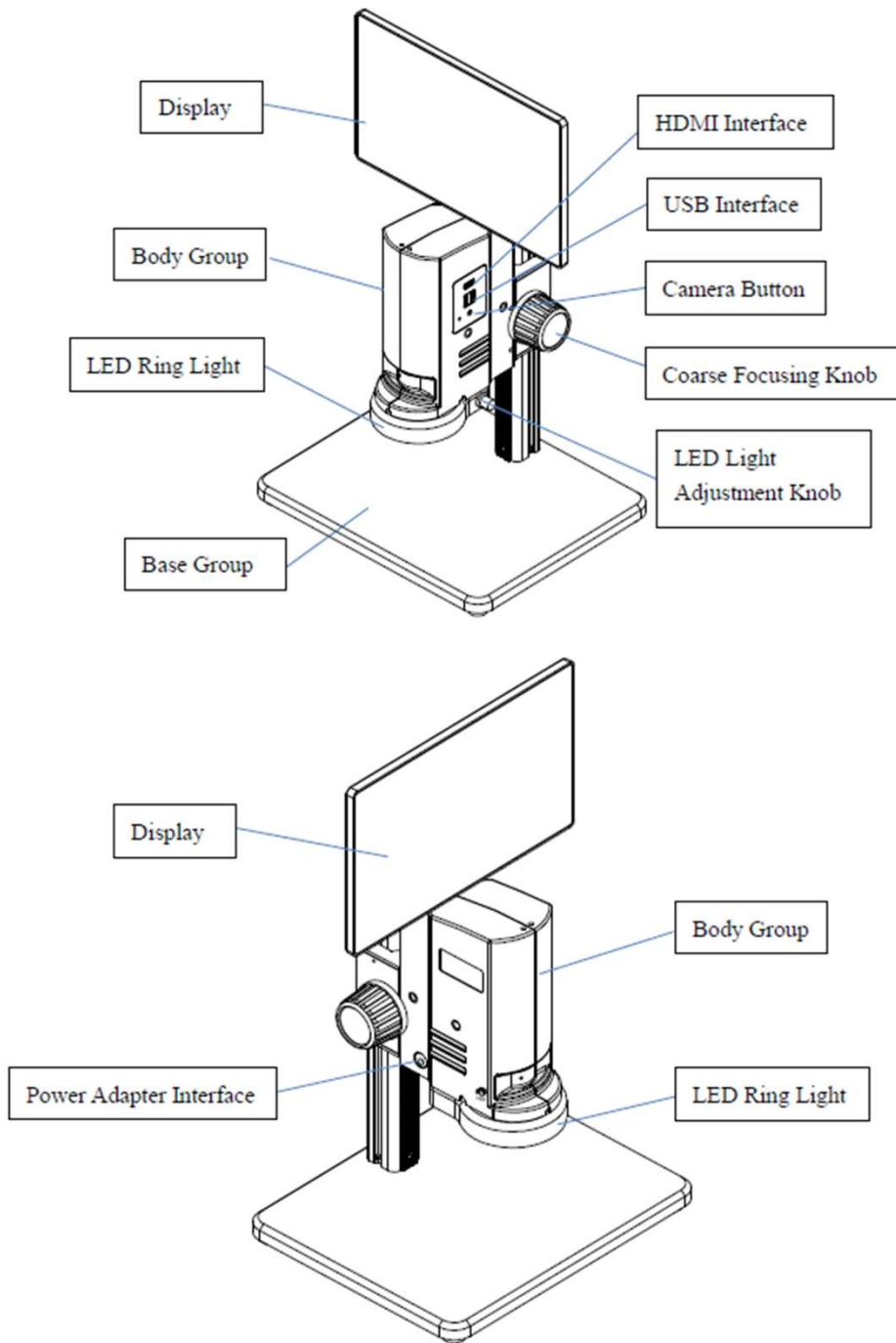

# ZoomHD DIGITAL MACRO ZOOM INSPECTION SYSTEM

## ZoomHD (without Display)

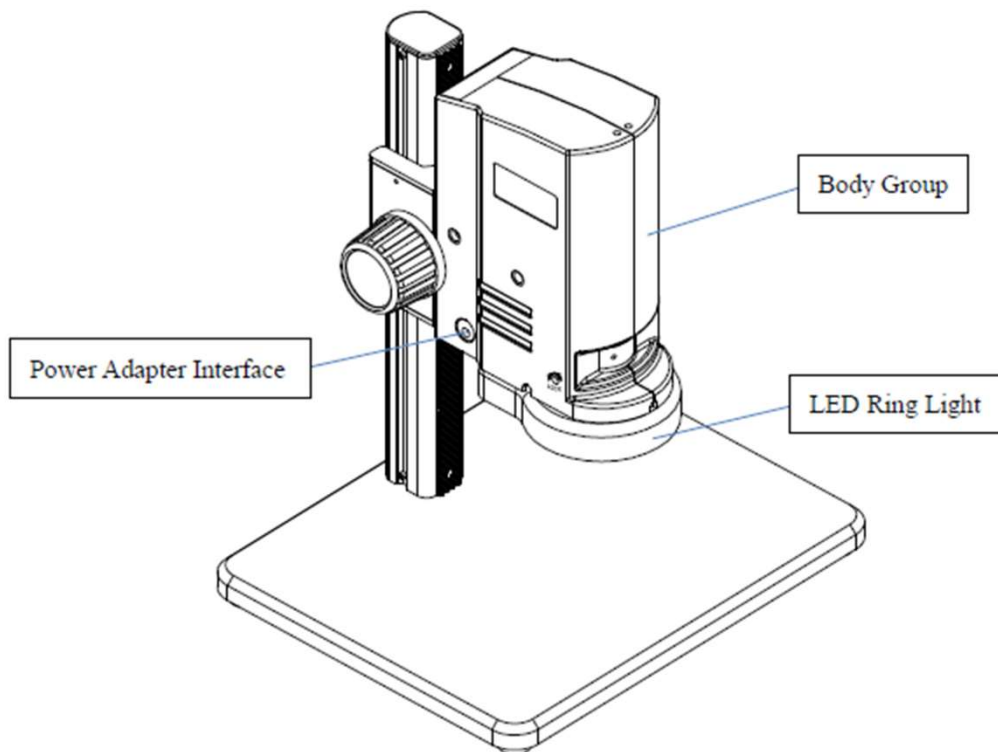
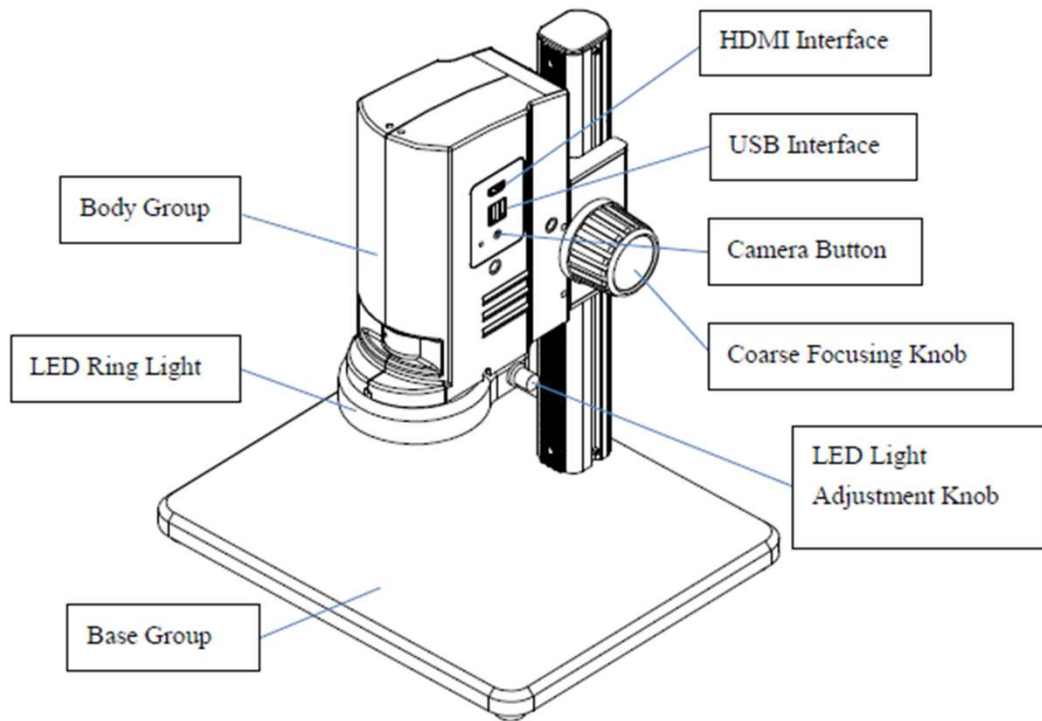

# ZoomHD DIGITAL MACRO ZOOM INSPECTION SYSTEM

## Assembly

The Assembly diagram below describes how to assemble the components, and numbers denote the assembly order.

★ Before assembling, make sure there is no dust, dirt or other materials which will disturb it. Assemble carefully and do not throw away any part, nor touch any glass surfaces.

★ Keep the 3mm hex wrench. It may be needed when changing parts.

### ZoomHD (with Display)

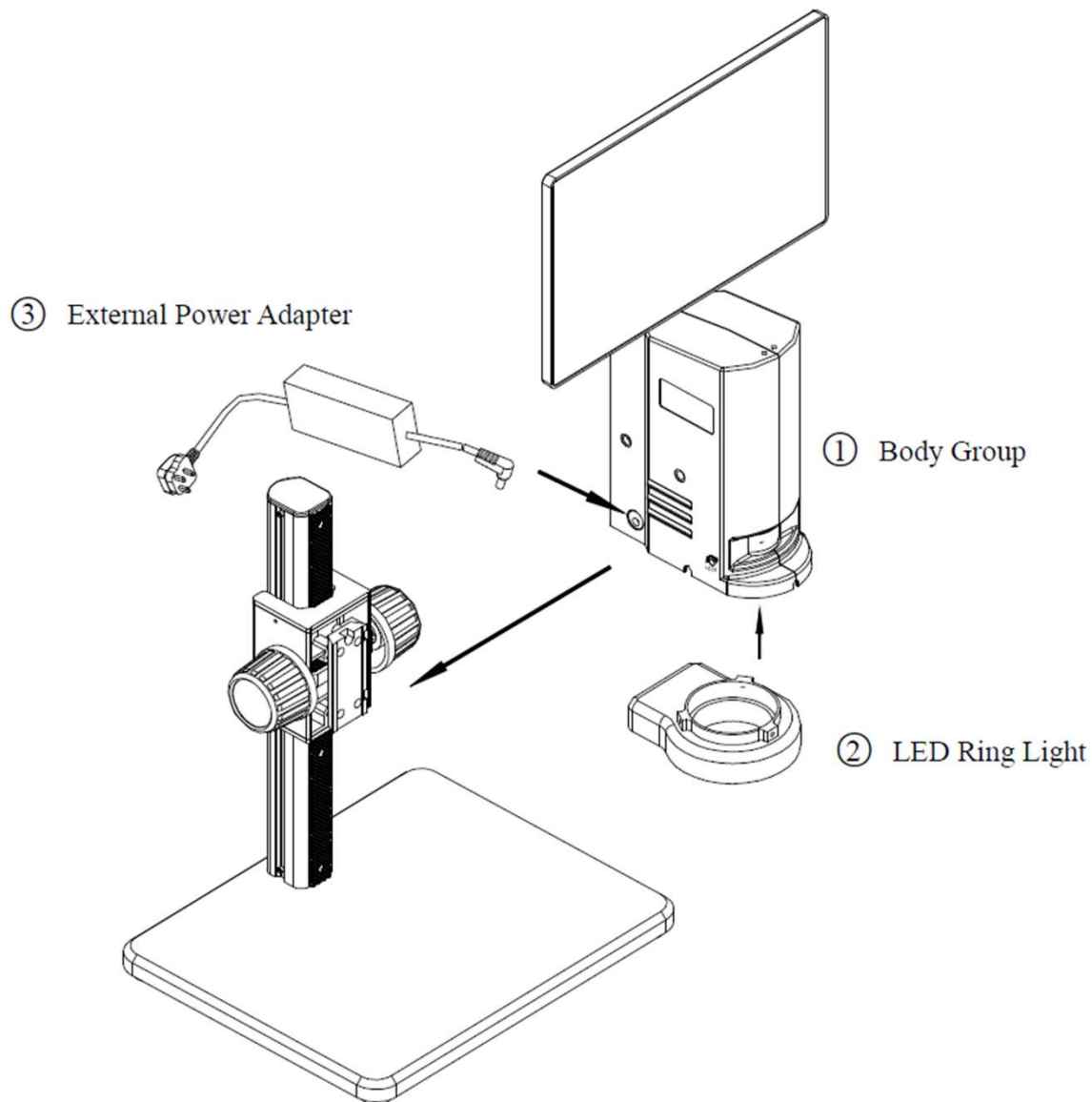

# ZoomHD DIGITAL MACRO ZOOM INSPECTION SYSTEM

## ZoomHD (without Display)

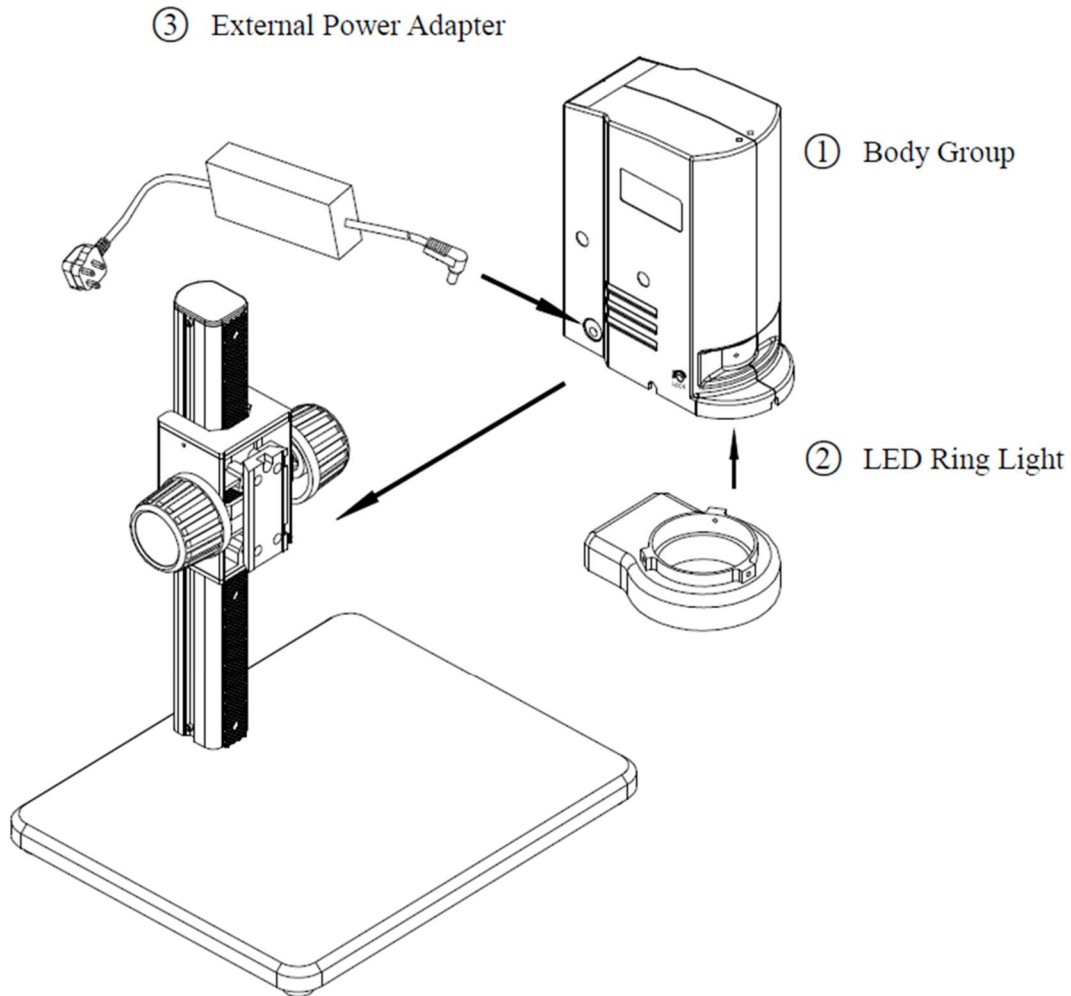

## Detailed Assembly

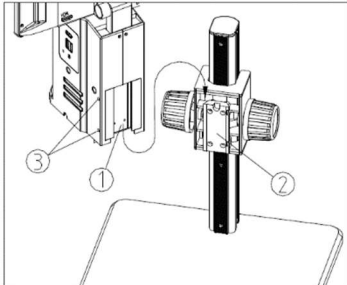

Fig. 1

### Assemble the Microscope Body

- 1) Match the dovetail interface ① of the microscope body with the dovetail groove ② of the focus bracket group, and insert it from top to bottom as the direction shown in the figure.
- 2) Tighten the inner hex screw on the body group ③ with the included hex wrench. (See Fig. 1)

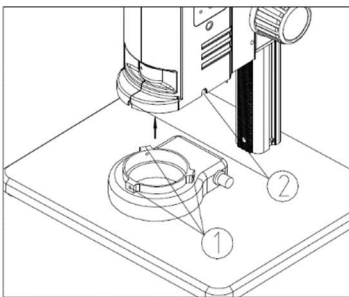

Fig. 2

### Assemble the LED Ring Light

- 1) Move the LED ring light close to the microscope body according to the arrowhead direction, and align the three screw holes ① with the thread groove ②. Lock the ring light into place by tightening the screw with the included hex wrench. (See Fig. 2).

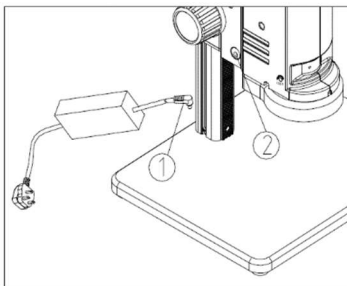

Fig. 3

### Connect the Power Cord

- 1) Insert the external adapter plug ① into the power supply adapter socket ② near the bottom of the microscope body. (See Fig. 3)

★ Don't use strong force when the power cord is bended or twisted, otherwise it will be damaged.

★ ONLY use the power cord supplied with your microscope. If it's lost or damaged, choose an external power adapter with the same specifications (power cord/charger).

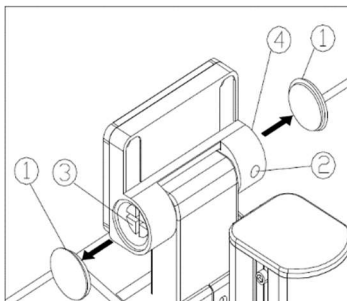

Fig. 4

### Adjust the screen's tilting tension (for systems with integrated display)

- 1) Open the cap nuts ① on both sides. Use Allen wrench to loosen the M3 hex screws ② from the cap screws ④, and use a flat screwdriver to tighten/loosen flat screws ④ to desired tension. Keep rotation axle ③ still using flat screwdriver. (See Fig. 4).
- 2) Tighten the M3 hex screws and replace the cap nuts.

★ A suitable screen tension is preset at the factory.

## Using Your ZoomHD

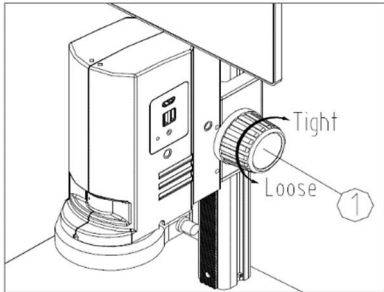

Fig. 5

### Adjusting the Focusing Tension

- 1) To adjust the focusing tension, grip and hold the left knob and rotate the right knob ①. Focusing tension will tighten when rotated in a clockwise direction, and loosen in counterclockwise. (See Fig. 5)
- 2) Adjust the focusing tension to the desired degree. Adjustment prevents the microscope body moving down the pillar when observing, and adjustment also makes focusing more comfortable.

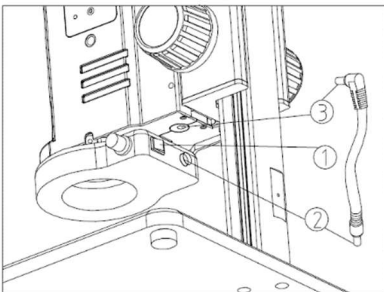

Fig. 6

### Setting Illumination

- 1) Insert one end of the power cord plug ② into the bottom of the body group, and the other end into the ring light ③. Turn on the switch ① to start the ring light. (See Fig. 6)
- 2) Rotate the light adjustment knob ④ to adjust the illumination brightness. Rotate the light adjustment knob clockwise to increase, and counterclockwise to decrease the brightness. (See Fig. 6 & Fig. 7)

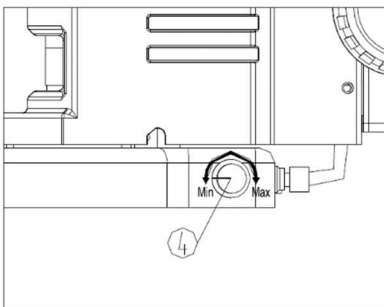

Fig. 7

### Placing the Specimen

- 1) Place the specimen on the base positioned exactly below the microscope.

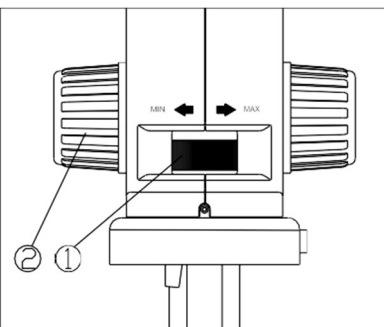

Fig. 8

### Adjusting the Focus

- 1) Rotate the zoom adjustment ring ① to the maximum magnification (highest number).
- 2) Observe the output image. If it is not sharp, rotate the focusing knob ② to make it sharp.
- 3) Rotate the zoom adjustment ring to the minimum magnification. Observe the output image to ensure it is sharp. (See Fig. 8)

★ High to low magnification parfocality is set to its optimal condition when this product is produced.

# ZoomHD DIGITAL MACRO ZOOM INSPECTION SYSTEM

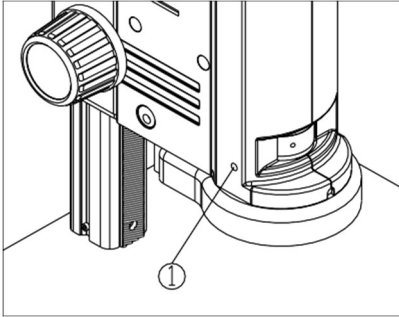
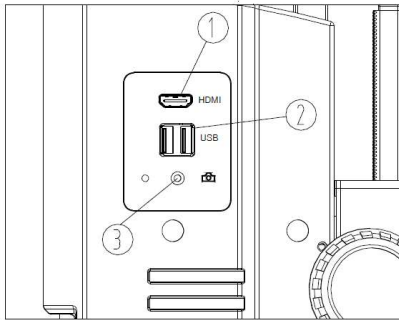

Fig. 9



## Fixing the Magnification

- 1) If using the same magnification repeatedly, tighten the magnification lock-screw ① with the hex wrench to hold that zoom magnification position. (See Fig. 9)
- 2) Loosen the lock screw before changing the magnification.

## Using the Button and Interface

★ **The camera is working when the indicator flashes.** (See Fig. 10)

- 1) HDMI cable interface ④, connect the HDMI cable to output the high definition image signal.
- 2) USB interface ⑤, connect the USB cable with the devices as mouse and USB stick.
- 3) Camera button ②, when the camera is working, press once to take one photo. The photo is saved onto the user-supplied and installed USB stick.

## Troubleshooting

In case the microscope doesn't perform normally, the table below may provide some solutions.

PROBLEM	CAUSE	SOLUTION
Stain or dust is observed in the live or saved image.	Stains have accumulated on the specimen	Clean the specimen
	Stains have accumulated on the CCD surface	Clean the CCD surface
The live or saved image is not clear/sharp.	Stains have accumulated on the lens surface	Clean the lens
	Focusing is not correct	Adjust the focusing
The live video image doesn't display.	The power switch isn't on	Turn on the switch button of microscope body
	The external power cable isn't securely connected	Reconnect the external power cable
The image is too bright or too dark.	The LED ring light illumination is adjusted too high	Adjust the brightness of LED ring light
	Display properties are not appropriately adjusted	Open the display menu of settings to adjust the brightness
The display is unresponsive and/or flashes.	The microscope software has an error	Restart the microscope
The focus knob does not turn easily.	The lock-screw is too tight	Loosen the lock-screw
The image starts in focus, but the focus deteriorates during observation.	The focusing knob is too loose causing the focus to slip	Tighten the focus knob
The microscope doesn't zoom.	The zoom adjustment ring is locked	Loosen the magnification lock-screw
LED ring light does not illuminate when turned on.	No power	Check the connection of Power Cord
	The LED light is burnt out	Replace a suitable light source
LED light suddenly burns out.	Voltage is too high	Use a suitable external power adapter
The illumination brightness is insufficient.	Voltage is too low	Use a suitable external power adapter

## SERVICE

UNITRON® microscopes are precision instruments which require periodic servicing to keep them performing properly and to compensate for normal wear. A regular schedule of preventative maintenance by qualified service personnel is highly recommended. Your authorized UNITRON® distributor can arrange for this service. Should unexpected problems be experienced with your instrument, proceed as follows:

1. Contact the UNITRON® distributor from whom you purchased the microscope. Some problems can be resolved simply over the telephone.
2. If it is determined that the microscope should be returned to your UNITRON® distributor or to UNITRON® for warranty repair, pack the instrument in its original molded shipping carton. If you no longer have this carton, pack the microscope in a crush-resistant carton with a minimum of three inches of a shock absorbing material surrounding it to prevent in-transit damage. The microscope should be wrapped in a plastic bag to prevent dust from damaging the microscope. Always ship the microscope in an upright position; **NEVER SHIP A MICROSCOPE ON ITS SIDE**. The microscope or component should be shipped prepaid and insured.

### **LIMITED MICROSCOPE WARRANTY**

This microscope is warranted to be free from defects in material and workmanship for a period of five (5) years for mechanical and optical components and one (1) year for electrical components from the date of invoice to the original (end user) purchaser. This warranty does not cover damage caused in-transit, misuse, neglect, abuse or damage resulting from improper servicing or modification by other than UNITRON® approved service personnel. This warranty does not cover any routine maintenance work or any other work, which is reasonably expected to be performed by the purchaser. Normal wear is excluded from this warranty. No responsibility is assumed for unsatisfactory operating performance due to environmental conditions such as humidity, dust, corrosive chemicals, deposition of oil or other foreign matter, spillage or other conditions beyond the control of Unitron Ltd. This warranty expressly excludes any liability by Unitron Ltd. for consequential loss or damage on any grounds, such as (but not limited to) the non-availability to the End User of the product(s) under warranty or the need to repair work processes. Should any defect in material, workmanship or electronic component occur under this warranty contact your UNITRON® distributor or UNITRON® at (631) 543-2000. This warranty is limited to the continental United States of America. All items returned for warranty repair must be sent freight prepaid and insured to UNITRON Ltd., 73 Mall Drive, Commack, NY 11725 – USA. All warranty repairs will be returned freight prepaid to any destination within the continental United States of America. For all foreign warranty repairs, return freight charges are the responsibility of the individual/company who returned the merchandise for repair.